

## ORBIS™ MOUNTING BRACKETS INSTALLATION INSTRUCTIONS

Ensure that all relevant personnel read the points listed below and that a copy is passed on to staff involved with the installation. Please also refer to the 'Manual Handling Operations Regulations 1992' during the handling of the product and materials used for installation.

### Kit Contents:

Item 1	Orbis Mounting Bracket	x 1
Item 2	M8 x 80mm Socket Button Screw	x 4 per Orbis
Item 3	M8 Nyloc Nut	x 4 per Orbis
Item 4	M8 x 20mm Washer	x 8 per Orbis

### Tools Required:

12mm Spanner  
6mm Allen Key

1. First align the open side of the Orbis Mounting Bracket (Item 1) with the holes in the post. Then attach the orbis to the post by passing 4 socket button screws (Item 2) and washers (Item 4) through the post, the bracket and finally into the Orbis fixing points (Fig. A).
2. Fasten each Socket Button Screw (Item 2) with a Nut (Item 3) and a Washer (Item 4) using the Allen key and Spanner (Fig. B).
3. Repeat the process with each additional Orbis to complete the Duo, Trio or Quad arrangement (Fig. C).

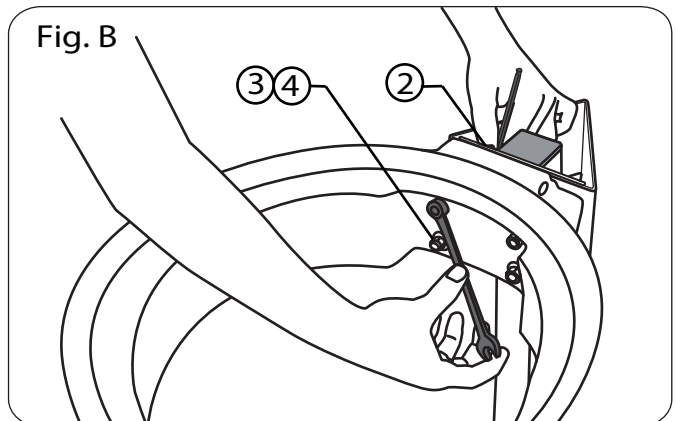
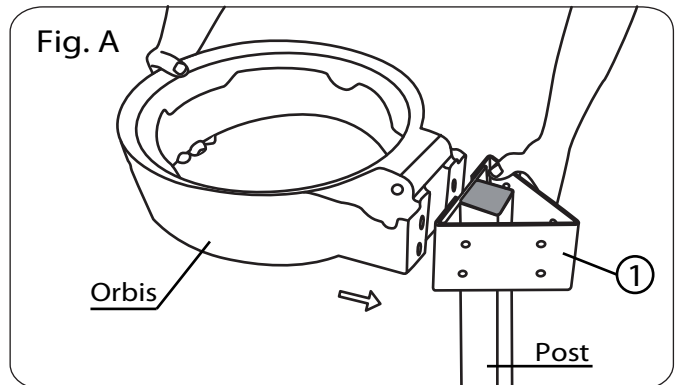

Fig. C

